



# M10, M12 & M16 Threaded Fiber Optic Feedthrough

## Hermetic Fiber Optic Feedthrough with FC Female Interface



Adapter Interface	FC/APC or FC/PC (SS 304L, female)
Threaded Housing	M10, M12, M16 or customized
Type of Fiber	SM (VIS, NIR), MM (UV, VIS, NIR), PM (VIS, NIR)
Hermeticity [mbar.l/s]	$10^{-10}$ to $10^{-12}$
Insertion Loss [dB]*	Max. 0.8 (typ. 0.5) @ 1310/1550 nm
Operating temperature [°C]*	-25 to +180

\* Depends on the fiber type

Threaded feedthroughs are mainly suitable for use in vacuum and in some cases also in positive pressure applications. The construction ensures fast and permanent seal in the chamber wall by tightening nut. The feedthrough assembly consists of M10, M12 or M16 housing with O-ring, nut and single-channel feedthrough with FC female interface. Customized solutions are available. Fiber optic feedthroughs contain fully replaceable/removable connector interface including an inner mating sleeve. Versions with polarization maintaining fibers (PMF) are also available.

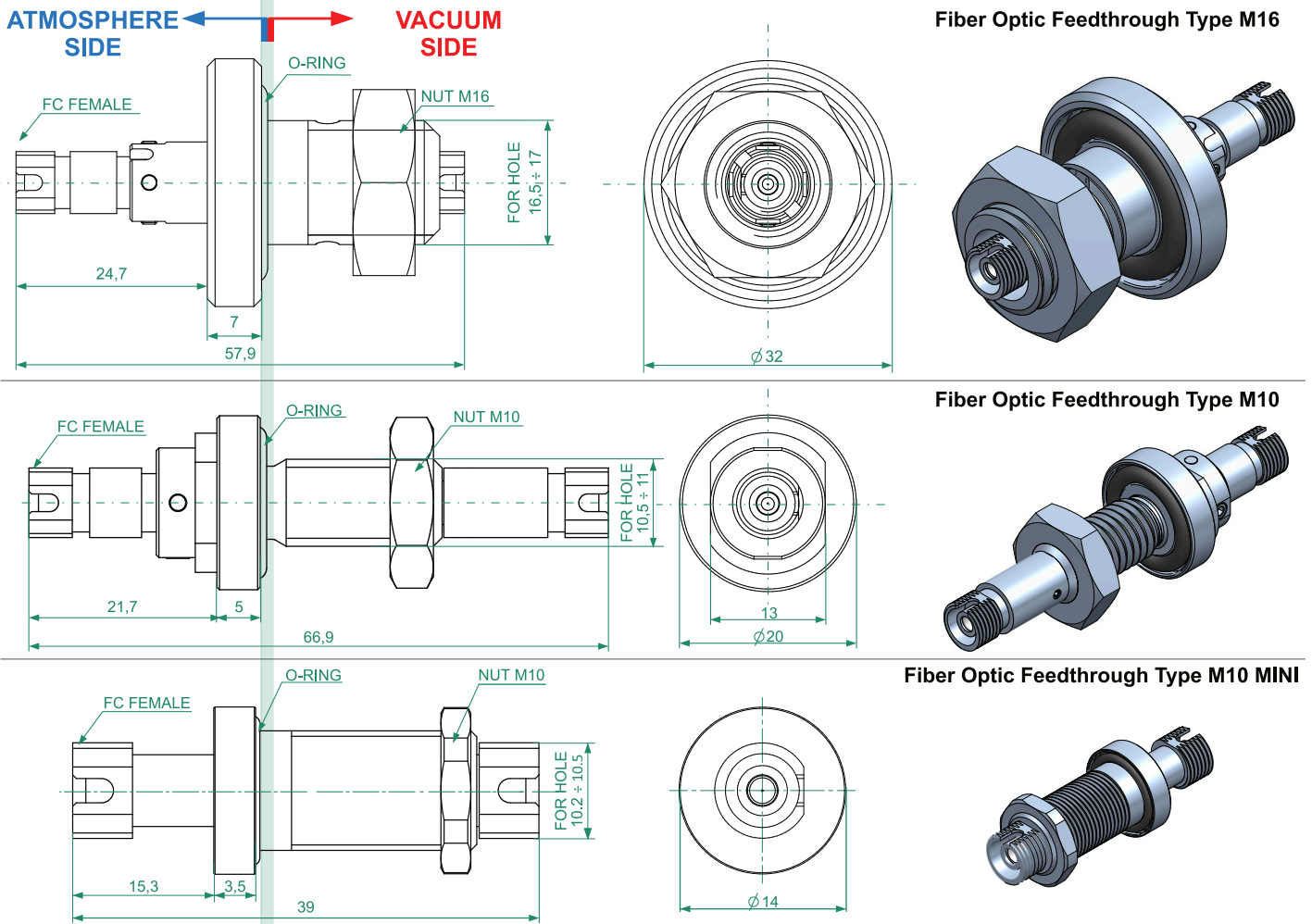

M16 Threaded Fiber Optic Feedthrough



M10 Threaded Fiber Optic Feedthrough



M10 Threaded MINI Fiber Optic Feedthrough

