



Vacuum Adapter Fiber Optic Feedthrough Without Flange

Hermetic Fiber Optic Feedthrough with Adapter Interface



Adapter interface (female)	FC/APC, FC/PC, SMA 905 or ST/PC
Fiber type	SM (VIS, NIR), MM (UV, VIS, NIR), PM (VIS, NIR)
Hermeticity [mbar.l/s/l]	10^{-10} to 10^{-12}
Housing material	Stainless steel 304L, other
Insertion loss [dB]	max. 0,8 (typ. 0,5) @1310/1550nm*
Operating temperature [°C]	-40 to +200, -20 to +70 (PM version)
Sealing in panel	Viton O-ring or laser welded

*) Other wavelenghts are available

Vacuum feedthroughs without flange are designed to be welded or assembled into a panel directly in application. The feedthrough for panel mounting is suitable for wall thickness 5-7mm and a hole diameter 8mm. The feedthrough is sealed by Viton O-ring and fully changeable on the customer side. The weldable feedthrough is primary offered for a wall thickness of the flanges KF and CF. However, both feedthroughs can be dimensionally adjusted on based customer request. Adapter interfaces including internal zirconia mating sleeves can be easily replaced. The developed technology allows working with different types of fibers including polarization maintaining fibers (PM).

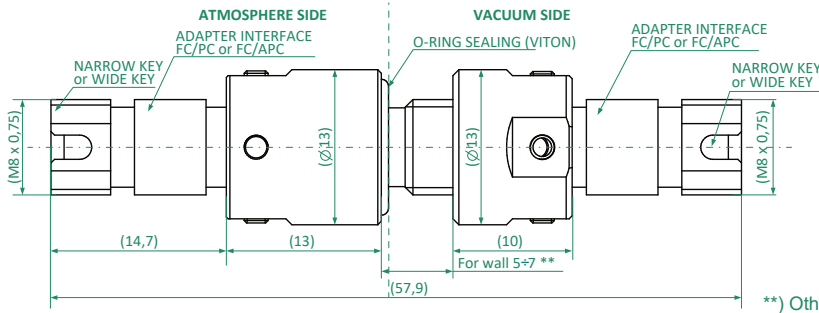

**) Other thicknesses are available

Feedthrough for panel mounting

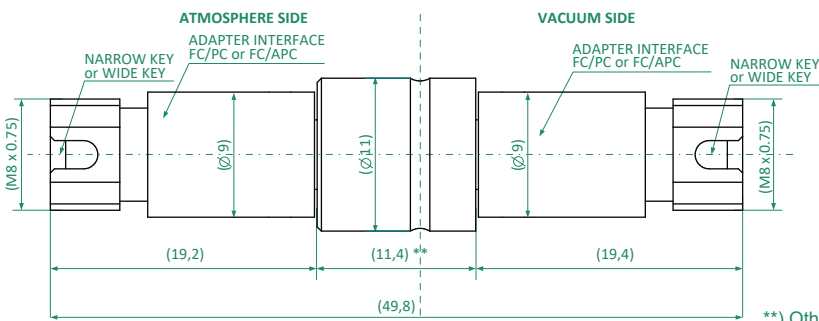
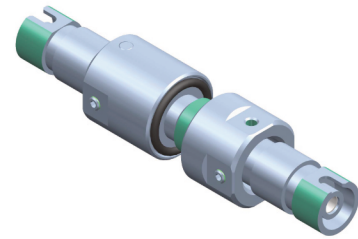

**) Other thicknesses are available

Weldable Feedthrough

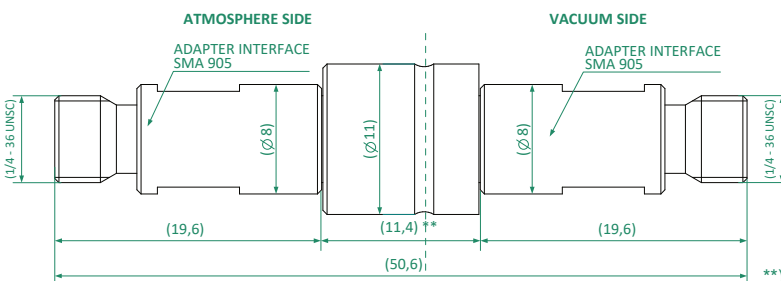
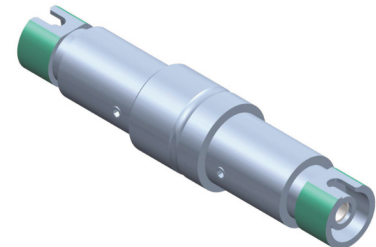

**) Other thicknesses are available

Weldable Feedthrough

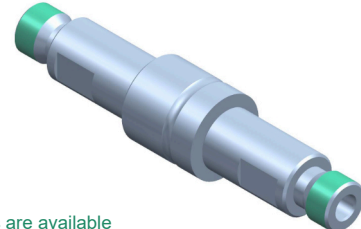

Feedthrough for Panel Mounting FC Interface



Weldable Feedthrough, FC Interface



Weldable Feedthrough, SMA 905 Interface

